

Ceramic Chip Antennas vs. PCB Trace Antennas: A Comparison

by Jouni Lifländer, RF Designer, Pulse Finland Oy

Multi-purpose machine-to-machine devices require a high quality radio interface that will operate in the Zigbee, ISM, and cellular bands including LTE, bands which lie between 700 and 2500 MHz. A trace antenna on a printed circuit board (PCB) is often the first type of interface considered for one of these applications. However, using a ceramic antenna can be a good or even better alternative.

The purpose of a trace antenna on a PCB is to provide a method of wireless communication. During the manufacture of the PCB, the trace is laminated on the PCB's surface or, in some cases, the traces can occupy several layers of a multilayer board. In these cases, vias are used to interconnect the traces on each layer. Feeding the antenna is normally arranged with a micro-strip line from the radio module.

Using a trace antenna has several advantages:

- Manufacturing costs are relatively low as the trace is applied as part of the PCB assembly process.
- The structure is extremely simple and, because the antenna is on the surface of the PCB, the structure profile is very thin.
- Optimally designed trace antennas have a large bandwidth.
- They're a good solution for sized-optimized PCBs in a stable environment.

Some of the disadvantages are that trace solutions do not work well if:

- The available PCB area for the antenna is small.
- Objects are too close to the antenna area on the PCB.
- They come in contact with, or are in close proximity to, people

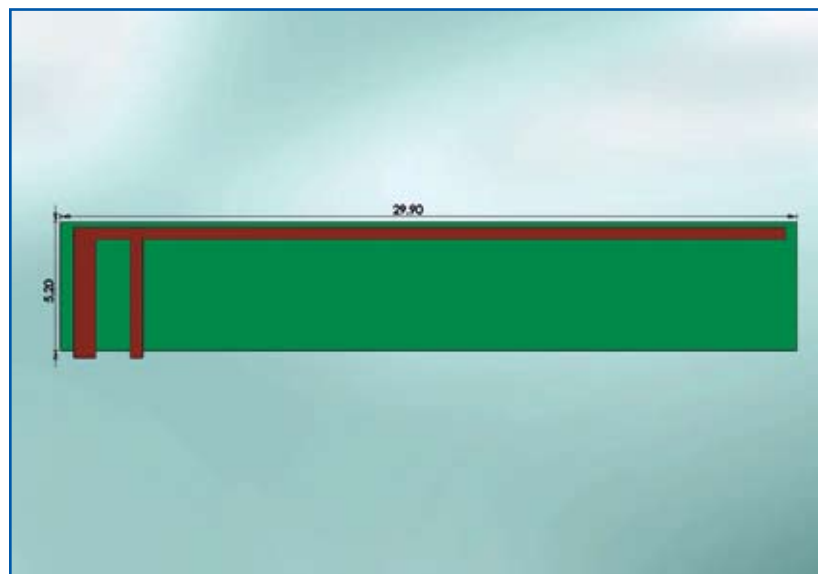

Figure 1: A trace solution for a 2.45 GHz antenna that uses an area of 29.90 x 5.20 mm. An equivalent ceramic chip antenna uses a ground clearance area of 6.25 x 4.24 mm. This equates to an 80% reduction in PCB space.

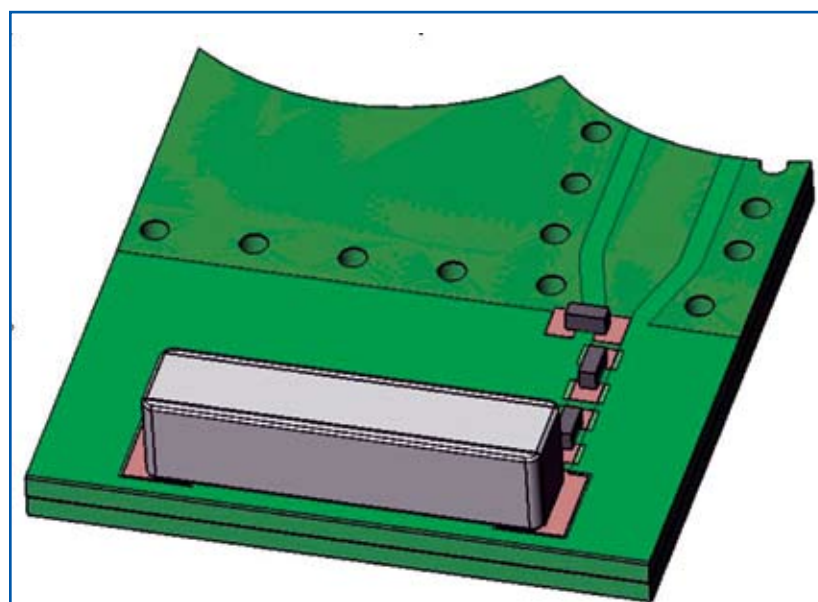

Figure 2: A layout and tuning for a monopole ceramic antenna which can be tuned to 2.4GHz or 866MHz and takes up an area of only 6 x 11mm².

- during operation.
- The antenna performance and tuning are significantly affected by the PCB design. Because of this, the tuning needs to be checked/adjusted after each change made to the PCB layout.

A PCB trace antenna will perform well if there is sufficient antenna clearance (area free of copper pour) on the PCB, if the device structures on the PCB are far enough from the

antenna, and if the environment in which the antenna operates is not influenced by external disturbance. This is generally the case with applications where there are relatively large devices (and PCBs) that don't require a human operator.

Even when using a thin profile trace solution, because the trace antenna is made from material with a low dielectric constant (a typical value of ϵ_r for an FR4 PCB is ~4), a significant reduction in performance will be seen due to its close proximity to metal

structures such as shielding, the chassis, batteries, displays, or other large electrical components. The antenna is easily detuned by environmental effects or human contact.

The trace antenna is implemented as a part of the PCB manufacturing process, which allows fast and consistent antenna application in a high volume manufacturing environment. In general, the PCB manufacturing process is quite accurate and reliable. However, because of the inherent sensitivity of the antenna, even minor changes or very small tolerance variations on the PCB can cause unintended antenna center frequency detuning that will result in antenna performance variation or frequency shifting. Often those failures aren't caught until final test of the fully assembled PCB. In addition, because the trace antenna is applied in the PCB manufacturing process, there is little design flexibility or chance to "tweak" the antenna to optimize performance once it's applied. As a result, there are often a number of design iterations that result in an increased time to market and an associated loss of revenue.

Some designers have tried to compensate for these disadvantages by using a meandered trace line in an effort to achieve a smaller design. However, the area around the trace antenna still needs to be kept clear of other objects to maintain performance, so the total area required is always much greater than just the size of the trace.

Although in the right application a trace antenna may be the economical choice, in some applications it can actually be more expensive. If additional PCB area is needed to accommodate the antenna, it increases the overall cost of the PCB.

A ceramic antenna is a small antenna component made of ceramic material. There are

several types of ceramic antennas, each with its own characteristics. Examples of antennas made from ceramic material include monopoles, inverted F antennas (IFA), and planar inverted F antennas (PIFA).

Ceramic antennas offer the following advantages:

- They are separate components.
- Small sizes and a variety of configurations are available.
- Close proximity to other components doesn't cause as severe detuning as with trace antennas.
- Ceramics are less affected by environmental factors or human operators than trace antennas.
- Flexible tuning and testing options are possible.
- Design changes are more easily introduced.

Disadvantages of using ceramic antennas are:

- The initial cost of the antenna plus logistics can be higher than the cost of a trace antenna.
- Some level of RF expertise is needed for optimal implementation.

A ceramic antenna is a separate component that is attached during the final stage in the SMT process. As such, the characteristics of the circuit board can be taken into account while the antenna is being optimized. It can be more easily optimized during the R&D process and its specifications customized. When implemented correctly, the result is a reduction in time to market, reduced development costs, and enhanced revenues.

Ceramic antennas can be designed in both on-ground and off-ground styles, with on-ground antennas being somewhat taller. The optimal ceramic material composition for the antenna and the electrical specifications selected usually depend on the intended frequency or frequency combinations. These also have an effect on ceramic antenna dimensions. In a trace anten-

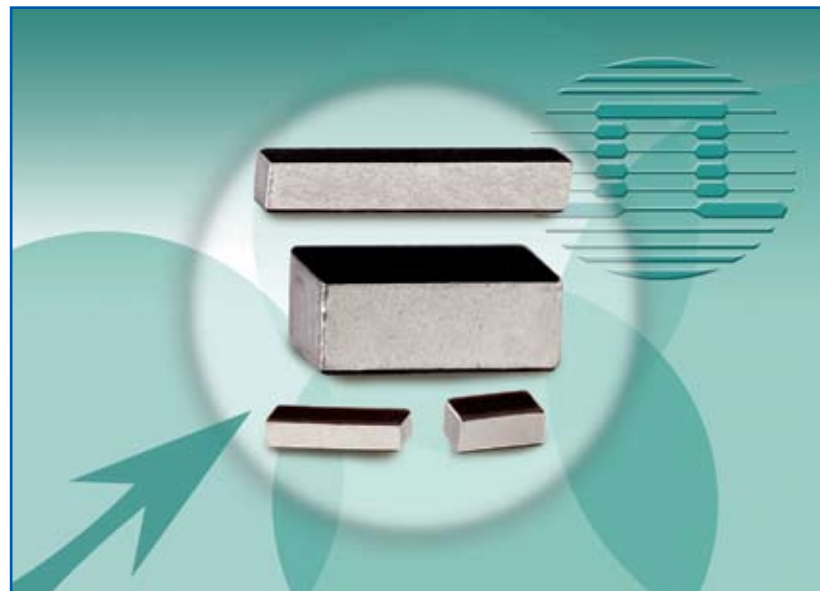

Figure 3: Monopole antennas

na, tuning options are limited as each option requires a separate iteration of PCB. Ceramic antennas can use matching circuits, optional ground clear areas, or a trace for coarse tuning, depending on the application.

With the desire to minimize the size of the PCB, using trace antennas creates a problem because they tend to require more PCB area than ceramic antennas. Ceramic antennas, on the other hand, can be adapted to small boards and offer flexibility for unique design layouts. The reliability and interference problems associated with being in close proximity to other components or people is greatly reduced with ceramics. Incorporating a separate antenna offers the option of utilizing the full available height of the device, making it possible to have a 3D structure with a smaller PCB area. Highly efficient antennas can be made using a very small antenna volume, such as a 2.4 GHz ceramic antenna that measures only 3.2 x 1.6 x 1.1mm. If it is possible to have ground clearance for the antenna on the PCB, the antenna can be made thinner without compromising its radiation efficiency, as would be the case in a situation where the antenna is placed on solid copper pour. The antenna's dimensions can be reduced significantly by choosing the antenna material according to the frequency of operation and

the area available on the PCB.

The extra board real estate gained by using a ceramic antenna allows for the use of additional components without increasing the board size. With multilayer PCBs in particular, each layer on the PCB needs to be cleared of any structures to reserve space for the antenna. Reducing the area required for the antenna reduces overall costs no matter what kind of antenna solution is being used. The more layers there are on the PCB, the more cost reduction a smaller antenna area provides.

Compared to a trace solution, a ceramic antenna will suffer less detuning from environmental effects. Separate antennas provide high antenna-to-antenna isolation in multi-radio systems and outperform trace antennas when the optimal antenna type is selected and correctly implemented.

Antenna performance always needs to be tested in the final, fully functional device using active over the air (OTA) measurements in an anechoic chamber. With trace antennas, test failures are expensive and difficult to fix and require several PCB iterations. Since the ceramic antenna is a separate component, it is easier and quicker to optimize using a single "final" PCB design. The tuning can be tweaked and the performance tested by changing only the antenna component on the board. When

R&D changes are necessary, the boards can still be used just by changing out the antenna. This is faster and less expensive than creating a new iteration of the PCB and retuning all the components, as is necessary with the trace antenna.

Ceramic antennas have been around for many years. The need for high performing, easy-to-implement antennas in machine-to-machine applications, like metering, has reawakened an interest in these highly efficient antenna structures. In these products, size constraints are more stringent and multiple antennas often need to be placed inside the same device, resulting in the need for high immunity between the antennas. Ceramic antennas enable flexibility in design, overall cost savings in the final product, have fewer problems with interference, and provide improved performance over trace antennas.

For more information on ceramic antennas or technical support for antenna design, visit our website:

www.pulseeng.com

About the Author

Jouni Lifländer, RF designer for Pulse Finland Oy, has worked at Pulse Kempele since 2008. He has a Bachelor of Engineering from Rovaniemi Polytechnic and a Masters in Engineering, specializing in radio engineering, from the University of Oulu in Finland.