



QorIQ LS1 Processor Family

# QorIQ LS1021A Communications Processor

Dual-core solution with integrated LCD controller for fanless applications

## Overview

The QorIQ LS1021A processor delivers extensive integration and power efficiency for fanless, small form factor networked applications. Incorporating dual ARM® Cortex®-A7 cores with ECC protection running up to 1.0 GHz, the QorIQ LS1021A is engineered to deliver over 5,000 Coremarks of performance, as well as virtualization support, advanced security features and the broadest array of high-speed interconnects and optimized peripheral features ever offered in a sub-3 W processor.

## Unparalleled Integration

The QorIQ LS1 family of devices was designed specifically to enable a new class of power-constrained applications by bringing together highly efficient ARM® cores and over twenty years of Freescale networking expertise and IP to offer the highest level of integration under 3 W. With ECC protection on both L1 and L2 caches, QUICC Engine support, USB 3.0, and a broad range of other peripheral and I/O features, the LS1 family of devices is purpose-built for multicore platforms that must perform more securely, intelligently and efficiently without sacrificing performance.

## Target Applications

- Enterprise AP routers for 802.11ac/n
- Multi-protocol IoT gateways
- Industrial and factory automation
- Mobile wireless routers
- Printing
- Building automation
- Smart energy

## QorIQ LS1021A Processor Block Diagram

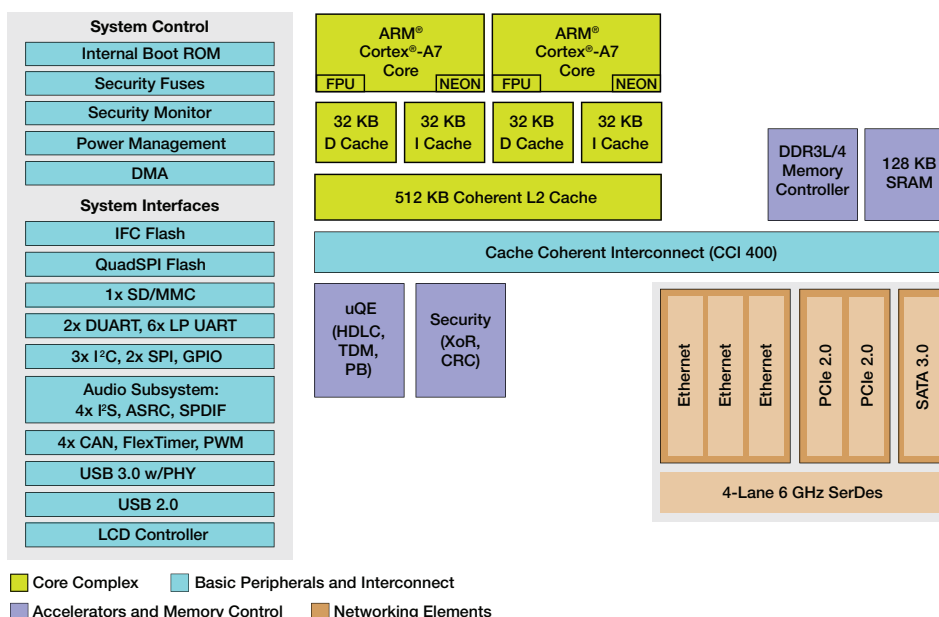

## Core Complex

The QorIQ LS1021A processor integrates dual ARM Cortex-A7 cores running up to 1.0 GHz with ECC protected L1 and L2 caches. Both cores feature 32 KB of L1 instruction and data cache, share up to 512 KB of coherent L2 cache, and feature the NEON SIMD module and dual precision floating-point unit (FPU). The DDR memory controller supports 8-, 16- or 32-bit type 3L and four memory devices at up to 1600 MHz.

## System Interfaces and Networking

A four-lane, 6 GHz multi-protocol SerDes provides support for high-speed interfaces, including up to three Gigabit Ethernet ports with IEEE® 1588 support, dual DMA controlled PCI Express® generation 2.0 ports and a single SATA 3.0 port. The LS1021A processor also features dual USB controllers—one supporting SuperSpeed USB 3.0 with integrated PHY, the other supporting USB 2.0 functions. Additional interfaces include QuadSPI, IFC and support for SD/MMC. For network audio applications, the LS1021A processor includes support for both ASRC and SPDF. For industrial applications, the processor provides four CAN ports and up to 10 UARTS to support industrial protocols. In addition, Serial IO includes three I<sup>2</sup>C and two SPI interfaces.

## Scalability

A key advantage of QorIQ processors built on Layerscape architecture is the complete compatibility of features, including virtualization and cache coherency, as well as ISA between various QorIQ LS1 devices. This, together with pin and software compatibility between the other LS1 devices—the LS1020A and LS1022A processors—enables customers to simply and smoothly migrate applications between next-generation QorIQ families.

## Complete Enablement, Rich Ecosystem

For customer evaluation, the QorIQ LS1021A processor is supported by the TWR-LS1021A

## QorIQ LS1021A Processor Features

Dual ARM Cortex-A7 cores	Extreme power efficiency, engineered to deliver over 5,000 CoreMarks®. Typical total system power of 3 W for improved performance without increased power utilization.
ECC-protected L1 and L2 cache memories	The QorIQ LS1 family devices are the only processors in their class with ECC-protected caches and coherent 512 KB L2, adding performance and meeting networking requirements for high reliability.
Integrated security engine, supporting Secure Boot and Trust Architecture	Based on the QorIQ SEC 5.5 hardware accelerated security engine, to provide in depth defense for customer applications
Rich connectivity and peripheral features, including PCI Express Gen 2, USB 3.0, SATA 3, IFC, QuadSPI, CAN	High versatility that enables support for 802.11ac modules and high bandwidth connectivity for ASICs, 4G/LTE, SATA and low-cost NAND/NOR Flash
LCD controller (2D-ACE)	Touchscreen support adds integrated HMI featured for enhanced ease of use and BOM savings. Similar IP as Freescale Vybrid controller solutions and i.MX applications processors to allow for simple software migration.
QUICC Engine	Proven support required for industrial, building and factory protocols such as PROFIBUS, HDLC and TDM
Support for hardware-based virtualization	Enables partitioning of CPU resources on low-power parts for increased system productivity
DDR3L/4	First in its class to offer support for DDR4 memory, ensuring continued performance efficiency

development platform, based on the modular Freescale Tower System, and features an integrated on-board probe for further cost savings. The TWR-LS1021A evaluation kit includes a Linux® 3.12 SDK with optimized drivers and a free 90 day evaluation license for CodeWarrior for ARM development tools.

All QorIQ LS series devices are supported by our extensive third-party ecosystem, the largest and most established in the communications market. In conjunction with our expertise and worldwide support infrastructure, the ecosystem helps customers accelerate their migration from both competitive solutions and from legacy Freescale devices, preserve investment costs and reduce time to market.

## CodeWarrior Development Suites for Networked Applications

LS Tower Suite Level: This suite was created to give you an economic, yet complete full-featured development tool for QorIQ LS development when the LS part is in a Freescale Tower Board configuration. The tools in this suite have no limitations other than they will only work with the Tower Board.

**Developer Suite Level:** This suite is the primary suite for customers who develop with multicore processors built on Power Architecture including, QorIQ LS series devices and QorIQ Qonverge SoCs as well as DSPs based on StarCore technology. It is for designers with full system responsibility but no need for the extra costs of the specialist and architect features.

**Specialists Suite Level:** This suite is designed so you can do more than just compile and debug. Tools in this suite are useful for customers creating products for every market. Get all the software included in the Developer Suite plus additional board-analysis tools. These tools can be used by all customers in any market but not everyone in a customer's organization needs these tools.

**Architect Suite Level:** This suite would best be used by personnel who have a need to dig deep into the networking aspects of a development project. In this suite, you will get all the software in the Specialist Suite plus software tools designed to give networking experts the extra capability to find out how their system is really working.

Learn more at [freescale.com/CW4NET](http://freescale.com/CW4NET)

## For more information visit [freescale.com/QorIQ](http://freescale.com/QorIQ)

Freescale, the Freescale logo, CodeWarrior and QorIQ are trademarks of Freescale Semiconductor, Inc., Reg. U.S. Pat. & Tm. Off. QUICC Engine, Tower and Vybrid are trademarks of Freescale Semiconductor, Inc. ARM is the registered trademark of ARM Limited. Cortex-A7 is a trademark of ARM Limited. All other product or service names are the property of their respective owners. © 2014 Freescale Semiconductor, Inc.

Document Number: LS1021AFS REV 1

