

Filter Design in Continuous Conduction Mode (CCM) of Operation; Part 2 Boost Regulator

Part two of this application note covers the filter design of voltage mode boost regulators running in continuous conduction mode (CCM). The focus of this application note is on the Bode plots of the output filter and how it affects stability in the overall boost regulator design. Diagram 1 shows a typical boost regulator output filter that is used in the analysis.

Boost Converter

Everything that applies to the buck regulator output filter in part one (ANP22) also applies to a boost converter. The differences are that a boost converter has a duty cycle relationship in its transfer function as well as a RHP zero which is also duty cycle related. Diagrams 2 and 3 show the phase and the gain of a boost regulator for the output filter in Diagram 1. The actual transfer function is derived by using State-Space Averaging Technique. Equation 1 is the duty cycle to output transfer function.

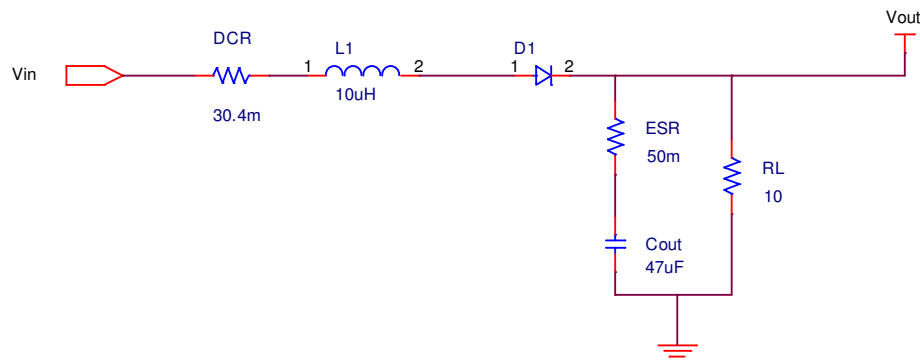

DIAGRAM 1 Boost regulator filter from part 1 of document

$$Boost_Filter(s) = \frac{(1 + s \cdot ESR \cdot Cout) \left[1 - \frac{L1}{RL \cdot (1-D)^2} \cdot s \right]}{\left[\frac{(L1 \cdot Cout)}{(1-D)^2} \cdot s^2 \right] + \left[\frac{Cout \cdot \xi}{(1-D)} \cdot s \right] + 1} \quad \xi = \left[\frac{DCR}{(1-D)} + ESR \right] \quad (1)$$

Filter Double pole is located at $LC_Filter = \frac{1-D}{2 \cdot \pi \cdot \sqrt{L \cdot Cout}} \quad (2)$

RHP zero located at $RHP_Zero = \frac{(1-D)^2 \cdot RL}{L \cdot 2 \cdot \pi}$ (3)

ESR zero occurs at frequency $f_{ESR_ZERO} = \frac{1}{2 \cdot \pi \cdot C_{out} \cdot ESR}$ (4)

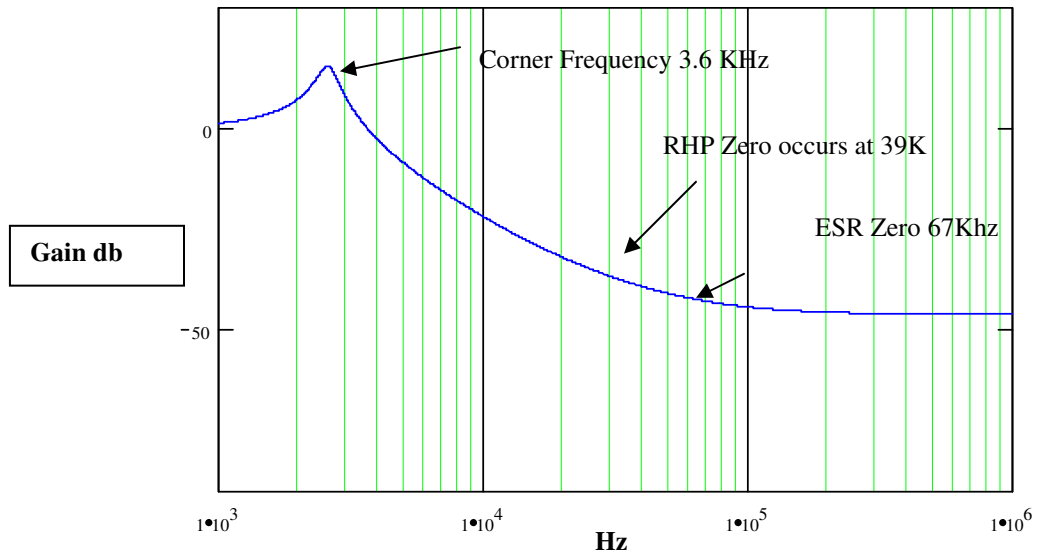

Diagram 2 Gain of a boost filter
Results for a boost regulator filter in diagram 1 the duty cycle was .5

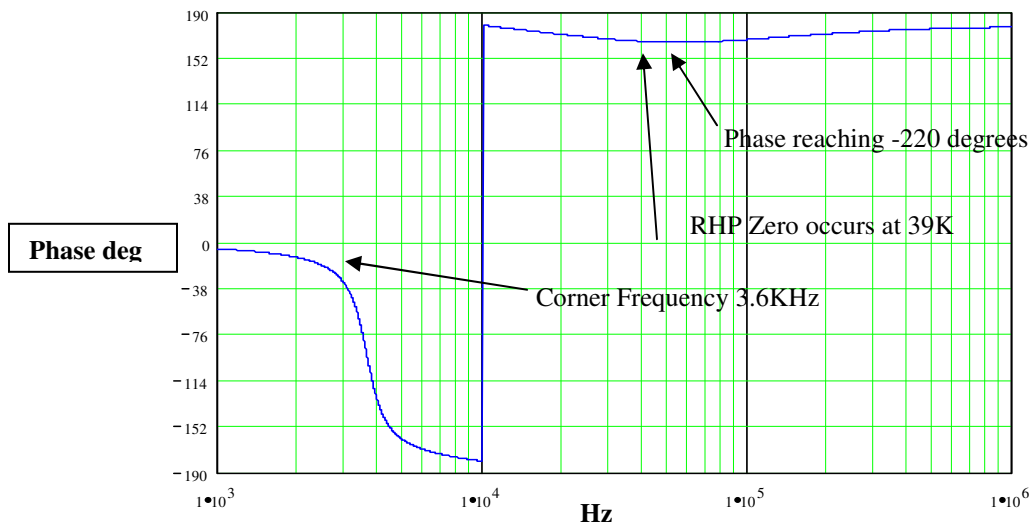

Diagram 3 Phase of a boost regulator in diagram 1 duty cycle=.5

The first thing that needs to be examined is the duty cycle variations on the Bode plot the second is to see what effect the load has. As can be seen from diagrams 2 and 3 duty cycle plays an important role in the shaping of the gain and phase of a boost regulator. When compensating such a regulator one needs to consider the operating conditions carefully.

Looking at the filter in diagram 1 then changing the duty cycle the results can be seen in diagrams 4 and 5.

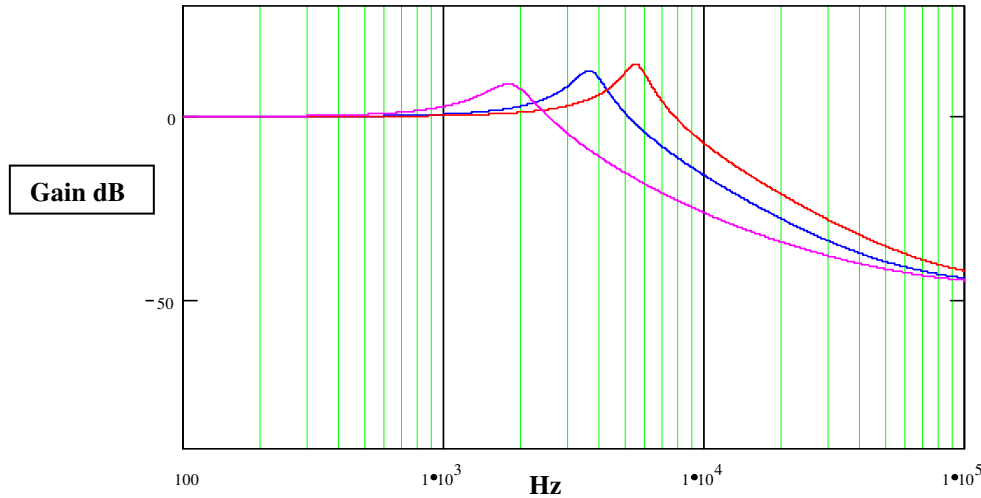

Diagram 4 Bode Plot Boost regulator Gain for different duty cycle

Magenta Duty cycle of .75
 Blue Duty cycle of .5
 Red Duty cycle of .25

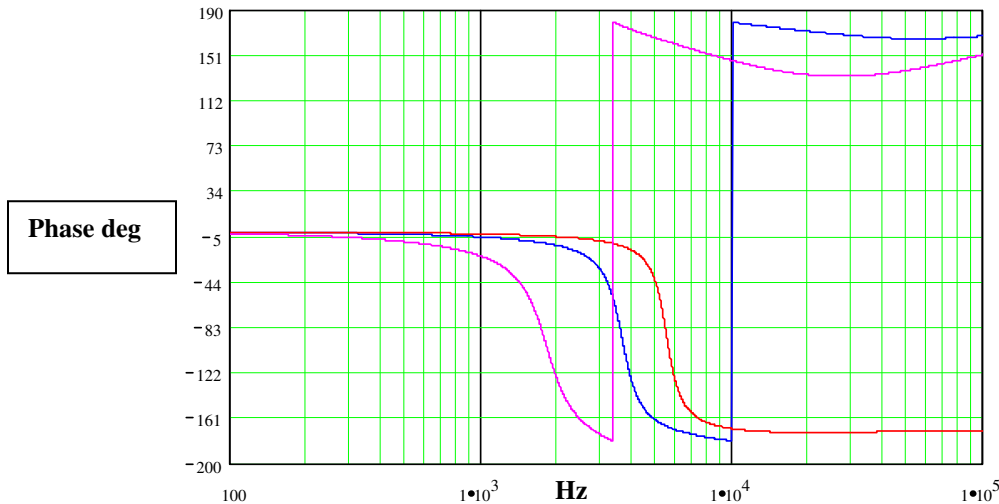

Diagram 5 Bode Plot Boost Regulator Phase for different duty cycle

Magenta Duty cycle of .75
 Blue Duty cycle of .5
 Red Duty cycle of .25

The next condition that needs consideration in the output filter is the load resistance condition. Load condition plays an important part in the location of the RHP zero which as stated earlier in this paper is detrimental to the phase of the system. In diagrams 6 and 7 there are several Bode plots for different loads keeping all of the other operating points constant.

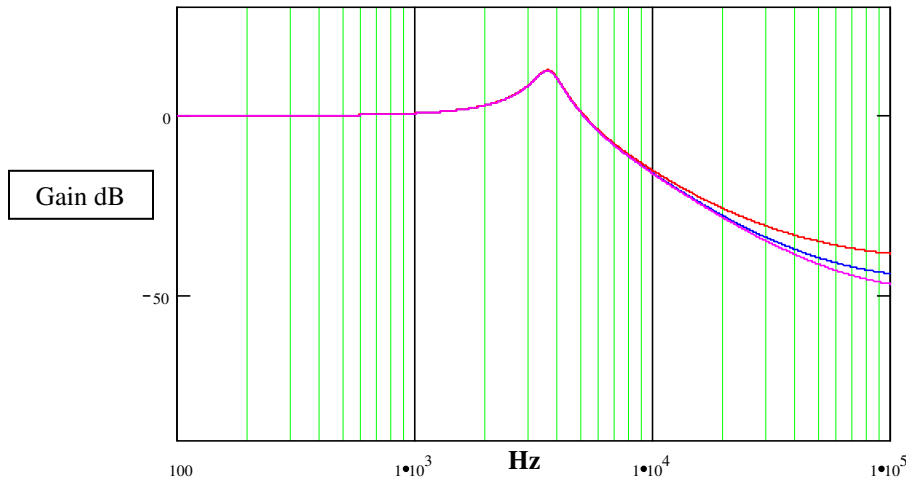

Diagram 6 gain of boost regulator with load resistance variations

Red RL is 5 ohms

Blue RL is 10 ohms

Magenta RL is 15 ohms

The gain of the boost regulator filter is shown in diagram 6. It can be shown that at high load, meaning low RL, the gain of the filter stops decreasing sooner. It should also be noted that the load does not have any effect on the location of the LC filter double pole. This is somewhat helpful when trying to design proper compensation for a boost regulator.

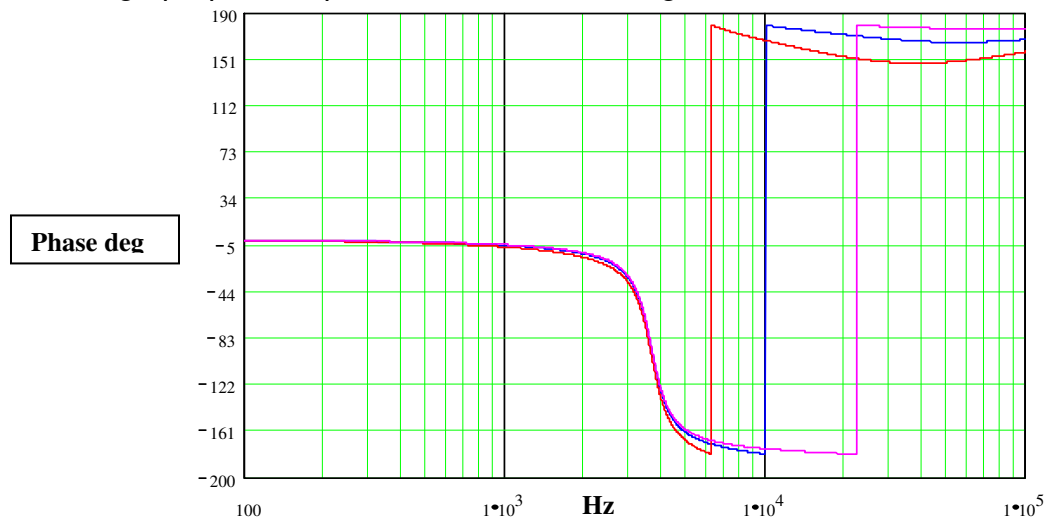

Diagram 7 Phase of a boost regulator load resistance variations

Red RL is 5 ohms
Blue RL is 10 ohms
Magenta RL is 15 ohms

As the load impedance is reduced the RHP Zero moves in closer and closer to the LC filter double pole hence two things will try to occur.

- 1 The phase will have a phase decrease that is much lower than a lower current output.
- 2 The decrease in phase also occurs at a faster rate.

The reason for this is that the ESR zero has less effect on the RHP zero counteracting the negative effects of the phase margin. But as stated before the LC filter double pole location where the phase starts decreasing does not change.

Boost regulator filter design considerations.

Just as in the buck regulator the approach to a good design of a boost regulator requires that the designer consider all of the conditions present. It should also be noted that most boost regulators will be compensated using either Type 1 or Type 2 compensation schemes. Using this type of compensation will typically limit the overall converter band width to fall below the LC filter double pole. This is because the compensation scheme needs to have unity gain way before the RHP zero takes effect to have a stable design.

When designing the output filter the main consideration is the location of the LC double pole. This allows for some simplification of the output filter design considerations. Since load resistance has no effect on the LC double pole location the designer can now consider the inductor and capacitor choices depending on different operating conditions as relating to the duty cycle. From equations 2, 3 it is shown that the inductor is a key element in the location of both the RHP and LC filter double pole. In Diagrams 8 and 9 we have a boost regulator running with different inductor values for the filter values below.

Filter $C_{out} = 47\mu\text{F}$, $\text{ESR} = 50 \text{ mohms}$, $R_L = 10 \text{ ohms}$ the duty cycle is .5

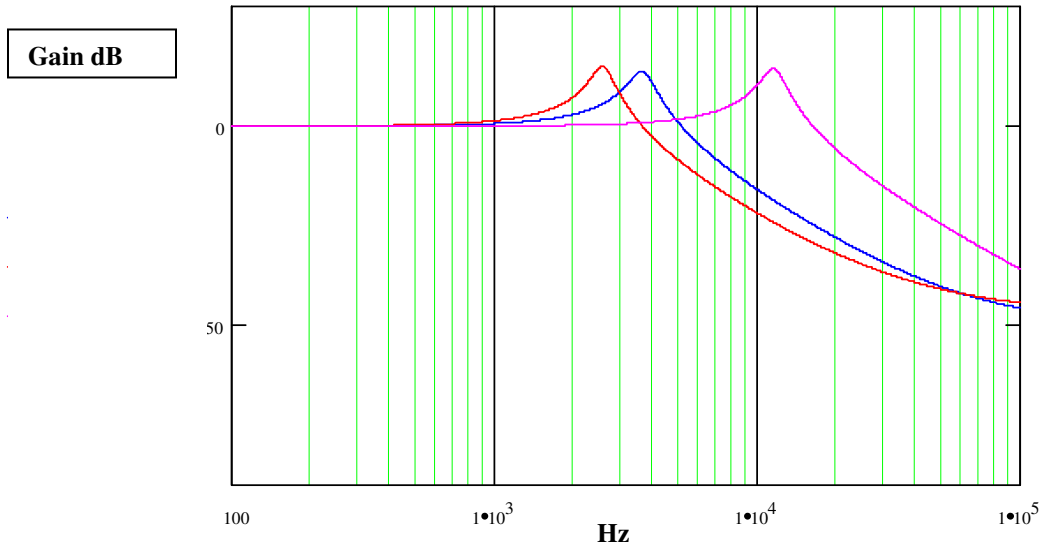

Red is 20uH
 Blue is 10uH
 Magenta is 1uH

Diagram 8 Example of different inductor values on the boost regulator filter

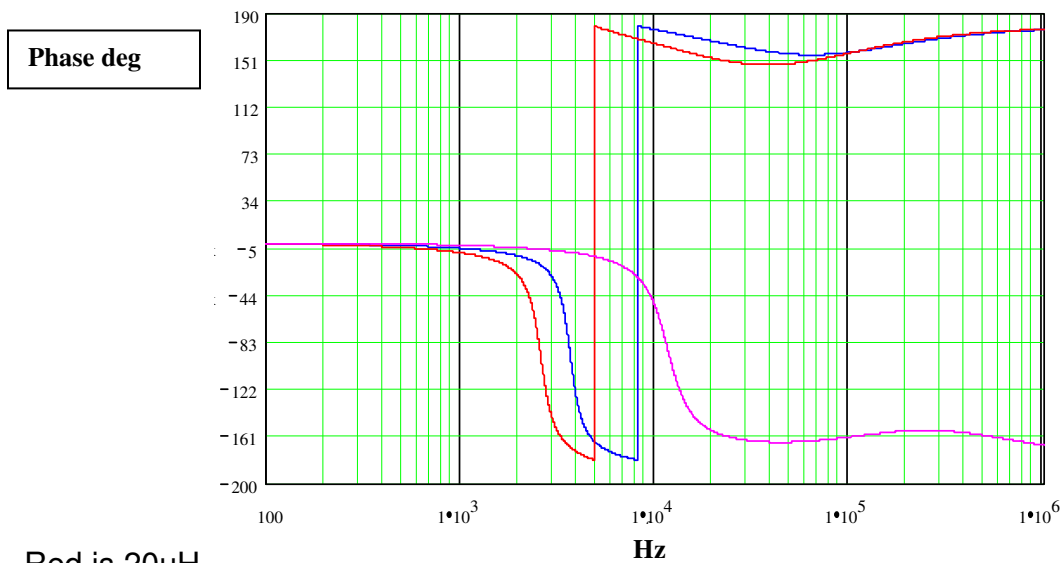

Red is 20uH
 Blue is 10uH
 Magenta is 1uH

Diagram 9 Example Boost regulator Phase with different Inductor values

An interesting observation is that as the inductor is smaller and smaller the RHP zero has less and less effect on the filter and the filter begins to look more and more like a buck regulator. This is actually verified in the fact that when a boost regulator runs in discontinues conduction mode the RHP disappears from the equation.

Thus it is desirable to actually use a small inductor. The drawback might be that small inductor values tend to generate higher peak current thus requiring lower ESR output capacitors.

Also when doing boost conversion it is better to have a limited duty cycle variations which also might affect the location of the filter double pole especially when running at higher duty cycles as shown in diagrams 4 and 5. The worst case occurs when the converter is running high duty cycle with high power.

Conclusion

In conclusion the filter design for a boost regulator seems like a more complicated task. But if proper care is taken it can be simplified greatly for most general applications. In many cases these general applications do not require extremely fast transient response hence the converter can be used with type I and type II compensation. If applications require extremely fast transient response but are derived from a lower input voltage, it might be better to use a boost converter and then do buck conversion which is more suitable to high transient applications.

Bibliography

- 1 Fred C Lee, A CPES Professional Short Course at Virginia Tech Lecture Note, Copy right 2005
- 2 Wu. Keng C. Pulse Width Modulated DC-DC Converters. New York: Chapman & Hall, 1997
- 3 John Van de Vegte Feedback Control Systems. New Jersey: Prentice Hall 1994
- 4 Savant, Roden, Carpenter Electronic Design Circuits and Systems 2nd edition. New York: Benjamin/Cummings Publishing Company, 1991